

Patented product
专利产品

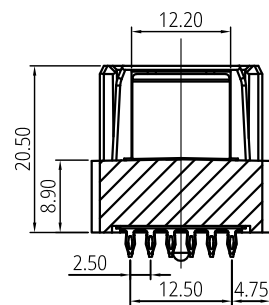

Section A-A

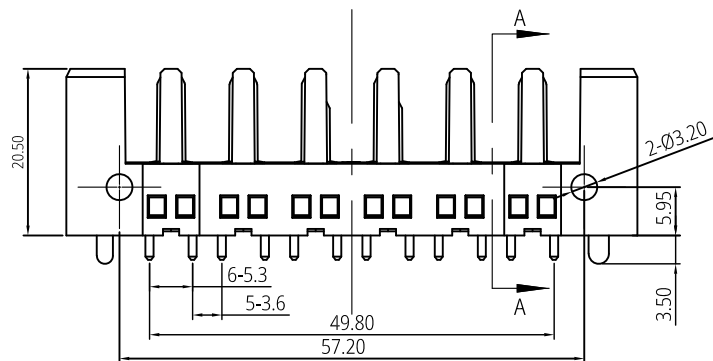
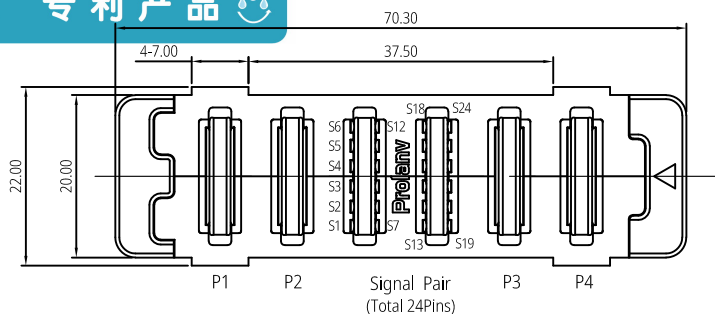
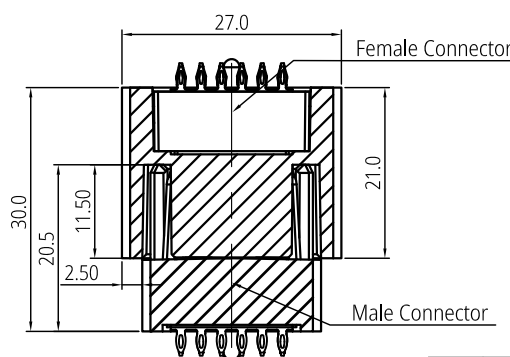
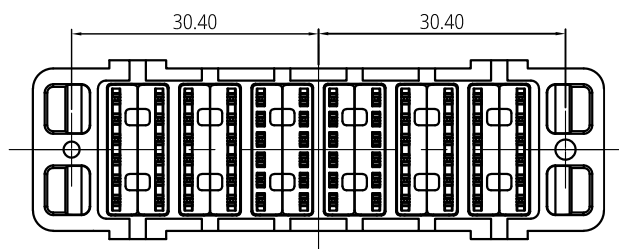

Mating View

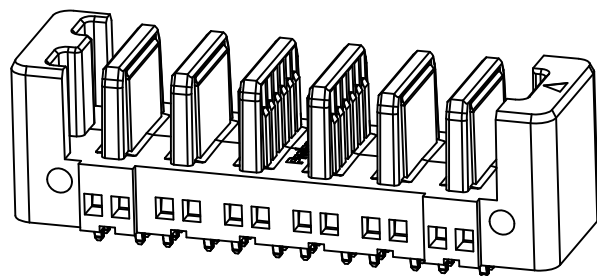

3D View

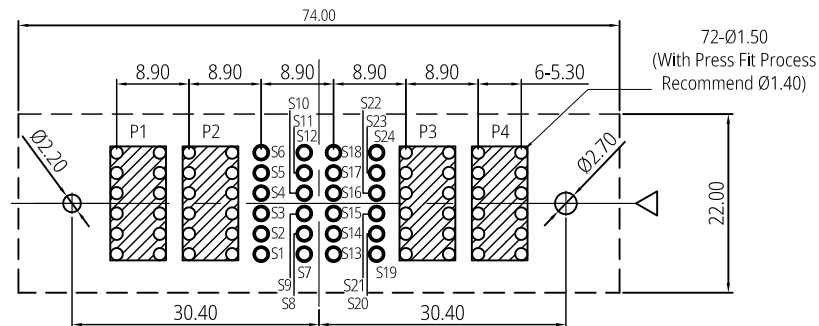

Recommended P.C.B layout (Top View)

Tolerance ± 0.05

Notes:

- Material Specification
 - Housing: High Temperature Thermoplastic. UL94 V-0, Black.
 - Contact: High Conductivity Copper Alloy.
- Plating Specification:
 - Contact: Gold plating on Contact area, matte Tin 80 μ " min. on Tails, and 50 μ " min, Nickel overall.
- Electrical performance
 - Voltage Rating: 600v DC/ 250V AC/Power Blade, 120V AC/DC /Signal Pin.
 - Current Rating: 150A Max./Per Power Blade, 7.5A Max/Per Signal Pin.
 - LLCR: initial 0.5m Ω max., finished 1.0m Ω maximum change.(per Power Blade) ; initial 10m Ω max., finished 20m Ω max.(per Signal Pin).
 - Dielectric Withstanding Voltage:
 - 2000v DC rms/Power Blade; 500v DC rms/Signal Pin.
 - Insulation Resistance: 5000 M Ω min/power blade;
- Mechanical Performance:
 - Insertion force: 39.2N (4.0kgf)/Per Pair, max.
 - Withdrawal force: 4.9N~34.3N (0.5~3.5kgf)/Per Pair.
 - Durability life: 5,000 cycles.
- IR Reflow:

The peak temperature on board shall be maintained for 10 seconds at 260 $\pm 5^{\circ}$ c.
- Operating Temperature Range: -40~125 $^{\circ}$ c(without loss function).
- All parts RoHS and Reach compliant.

THIS DRAWING AND SPECIFICATION ARE THE PROPERTY OF Prolanv AND SHALL NOT BE COPIED OR USED WITHOUT Prolanv PERMISSION

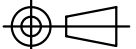
GENERAL TOLERANCES UNLESS SPECIFIED		PART NO.		Prolanv [®]							
X \pm 0.30	X. $^{\circ}$ \pm 3 $^{\circ}$	PDC3320F0001									
XX \pm 0.20	.X. $^{\circ}$ \pm 2 $^{\circ}$	APPROVED BY	TITLE								
XXX \pm 0.10	.XX. $^{\circ}$ \pm 1 $^{\circ}$	Mike	EX150 Series Hi-Current Power Male. H20.5mm, 4PW+24S Vertical Type								
CUSTOMER DRAWING		CHECKED BY	DWG NO.								
		Harry	PDC33-20								
SIZE	UNITS	DRAWN BY	 <table border="1"> <tr> <td>SHEET</td> <td>SCALE</td> <td>REV</td> </tr> <tr> <td>1 / 2</td> <td>1:1</td> <td>A2</td> </tr> </table>			SHEET	SCALE	REV	1 / 2	1:1	A2
SHEET	SCALE	REV									
1 / 2	1:1	A2									
A4	mm[only]	Poplar									

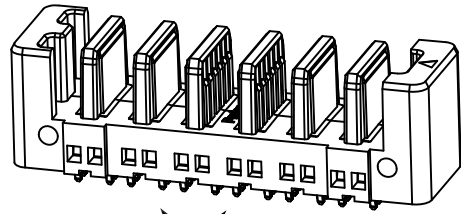

16Pcs/Tray

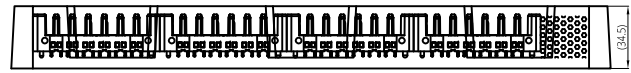
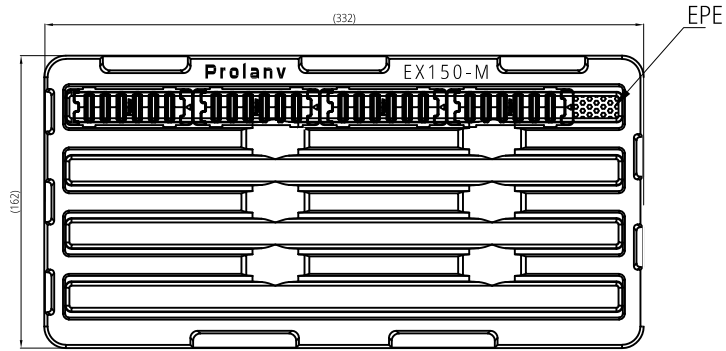

Notes:

1. Q'ty: 16 Pcs/Tray, 2x5 Layers=160 Pcs/Carton.
2. Tray Pallet size: 332*162mm.
3. Carton size: 350*350*155mm.

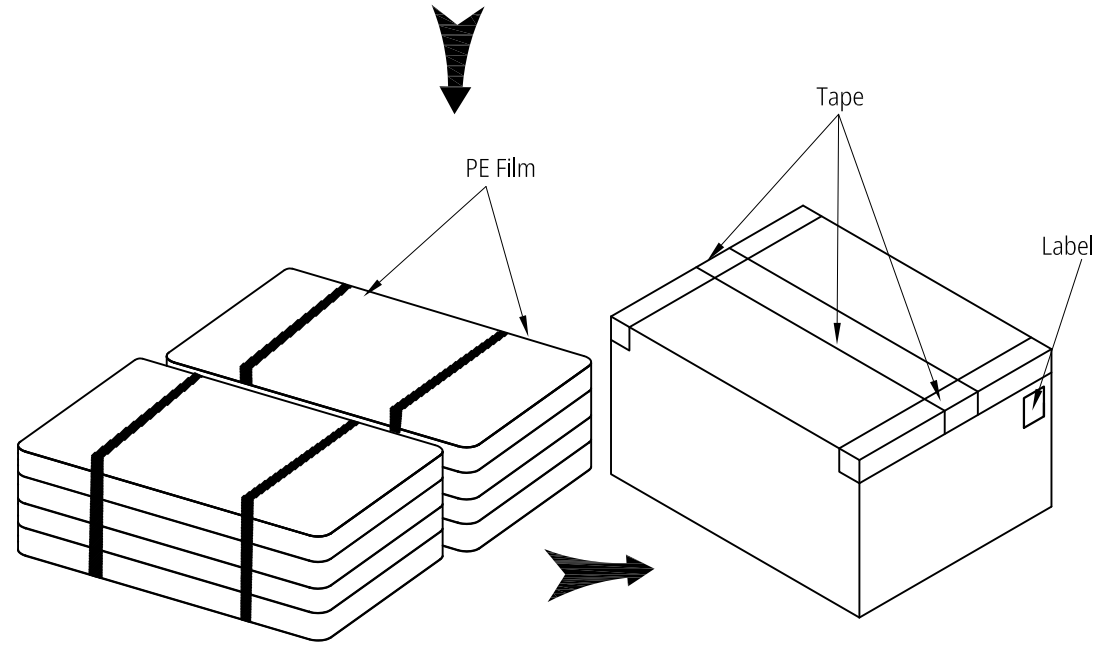
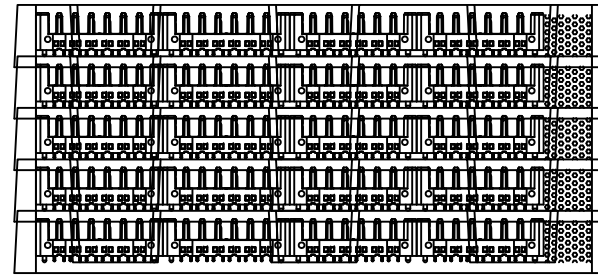

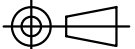
THIS DRAWING AND SPECIFICATION ARE THE PROPERTY OF Prolanv AND SHALL NOT BE COPIED OR USED WITHOUT Prolanv PERMISSION	GENERAL TOLERANCES UNLESS SPECIFIED		PART NO.	Prolanv [®]		
	X± 0.30	X°± 3°	PDC3320F0001			
	XX± 0.20	XX°± 2°	APPROVED BY	TITLE		
	XXX± 0.05	XXX°± 1°	Mike	EX150 Series Hi-Current Power Male. H20.5mm, 4PW+24S, Packaging		
	CUSTOMER DRAWING		CHECKED BY	DWG NO.		
			Harry	P-PDC33-20		
SIZE	UNITS	DRAWN BY		SHEET	SCALE	REV
A4	mm[only]	Poplar		2 / 2	N/A	A1