

- Notes:
- Material Specification:
 - Housing: LCP+30% G.F UL94 V-0.
 - Contact: Copper Alloy (C5210) T=0.15mm.
 - Leg: Copper Alloy (C2680) T=0.20mm.
 - Plating Specification:
 - Contact: see P/N.
 - Leg: Matte Tin 50µ" min. overall, Nickel 50µ" min. underplated.
 - Mechanical Performance:
 - Insertion force: 20N max.
 - Withdrawal force: 20N max.
 - Durability: 60 cycles min.
 - Vibration: No electrical discontinuity greater than 1u second. shall occur;
 - Mechanical shock: 285G half sine/6 axis. no electrical discontinuity greater than 1u second shall occur;
 - Electrical Performance:
 - Current Rating: 0.5A (per pin).
 - Voltage Rating: 50V AC (per pin).
 - LLCR: Contact 55mΩ max.(initial), 20mΩ max. change allowed (final).
 - Insulation Resistance: 5,000MΩ min. at 500V DC.
 - Dielectric withstand voltage: 300V AC/60s.
 - IR Reflow: The peak temperature on board shall be maintained for 10 seconds at 260±5°C.
 - Operating temperature range: -40°C~85°C(without loss function).
 - All parts RoHS and Reach compliant.

Part Number: PHN17101M00X

Contact Plating Spec. Code: _____

7: Gold Flash on Contact area, matte Tin 80µ" min. on Tails and 50µ" min. Nickel overall.

9: Au 5µ" on Contact area, matte Tin 80µ" min. on Tails and 50µ" min. Nickel overall.

A: Au 10µ" on Contact area, matte Tin 80µ" min. on Tails and 50µ" min. Nickel overall.

THIS DRAWING AND SPECIFICATION ARE THE PROPERTY OF Prolanv AND SHALL NOT BE COPIED OR USED WITHOUT Prolanv PERMISSION	GENERAL TOLERANCES UNLESS SPECIFIED		PART NO.		<h1>Prolanv®</h1>		
	.X± 0.30 X°± 3°		PHN17101M00X				
	.XX± 0.20 X°± 2°		APPROVED BY		TITLE		
	.XXX± 0.10 .XX± 1°		KYSIN		NGFF Socket (M.2 Connector) 0.50mm Pitch, Top-Mount 6.4H, STD. M-Key, Dual-SMT Type		
CUSTOMER DRAWING		CHECKED BY		DWG NO.			
		HARRY		PHN17-10M			
SIZE	UNITS	DRAWN BY			SHEET	SCALE	REV
A4	mm[only]	LUCIE			1 / 3	1:1	B3

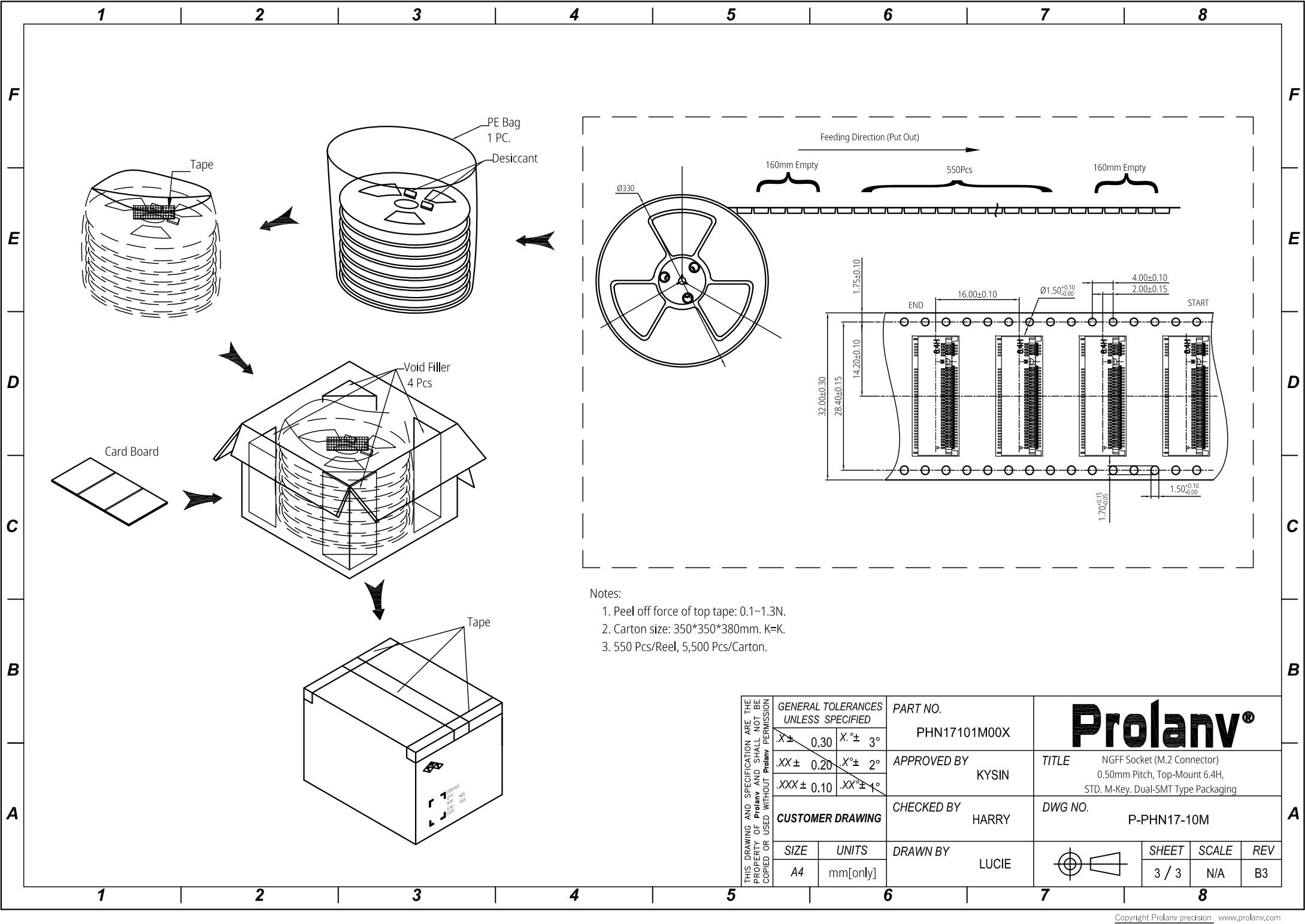

- Notes:
1. Peel off force of top tape: 0.1~1.3N.
 2. Carton size: 350*350*380mm. K=K.
 3. 550 Pcs/Reel, 5,500 Pcs/Carton.

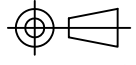
THIS DRAWING AND SPECIFICATION ARE THE PROPERTY OF Prolanv AND SHALL NOT BE COPIED OR USED WITHOUT Prolanv PERMISSION	GENERAL TOLERANCES UNLESS SPECIFIED		PART NO.		<h1 style="margin: 0;">Prolanv®</h1>						
	$X \pm 0.30$	$X^\circ \pm 3^\circ$	PHN17101M00X								
	$.XX \pm 0.20$	$X^\circ \pm 2^\circ$	APPROVED BY		TITLE NGFF Socket (M.2 Connector) 0.50mm Pitch, Top-Mount 6.4H, STD. M-Key. Dual-SMT Type Packaging						
	$.XXX \pm 0.10$	$.XX^\circ \pm 1^\circ$	KYSIN								
CUSTOMER DRAWING		CHECKED BY		DWG NO. P-PHN17-10M							
		HARRY									
SIZE	UNITS	DRAWN BY		 <table border="1" style="display: inline-table; margin-left: 20px;"> <tr> <td>SHEET</td> <td>SCALE</td> <td>REV</td> </tr> <tr> <td>3 / 3</td> <td>N/A</td> <td>B3</td> </tr> </table>		SHEET	SCALE	REV	3 / 3	N/A	B3
SHEET	SCALE	REV									
3 / 3	N/A	B3									
A4	mm[only]	LUCIE									